

Glazing Recommendations

REHAU TOTAL70 WINDOW AND DOOR SYSTEMS

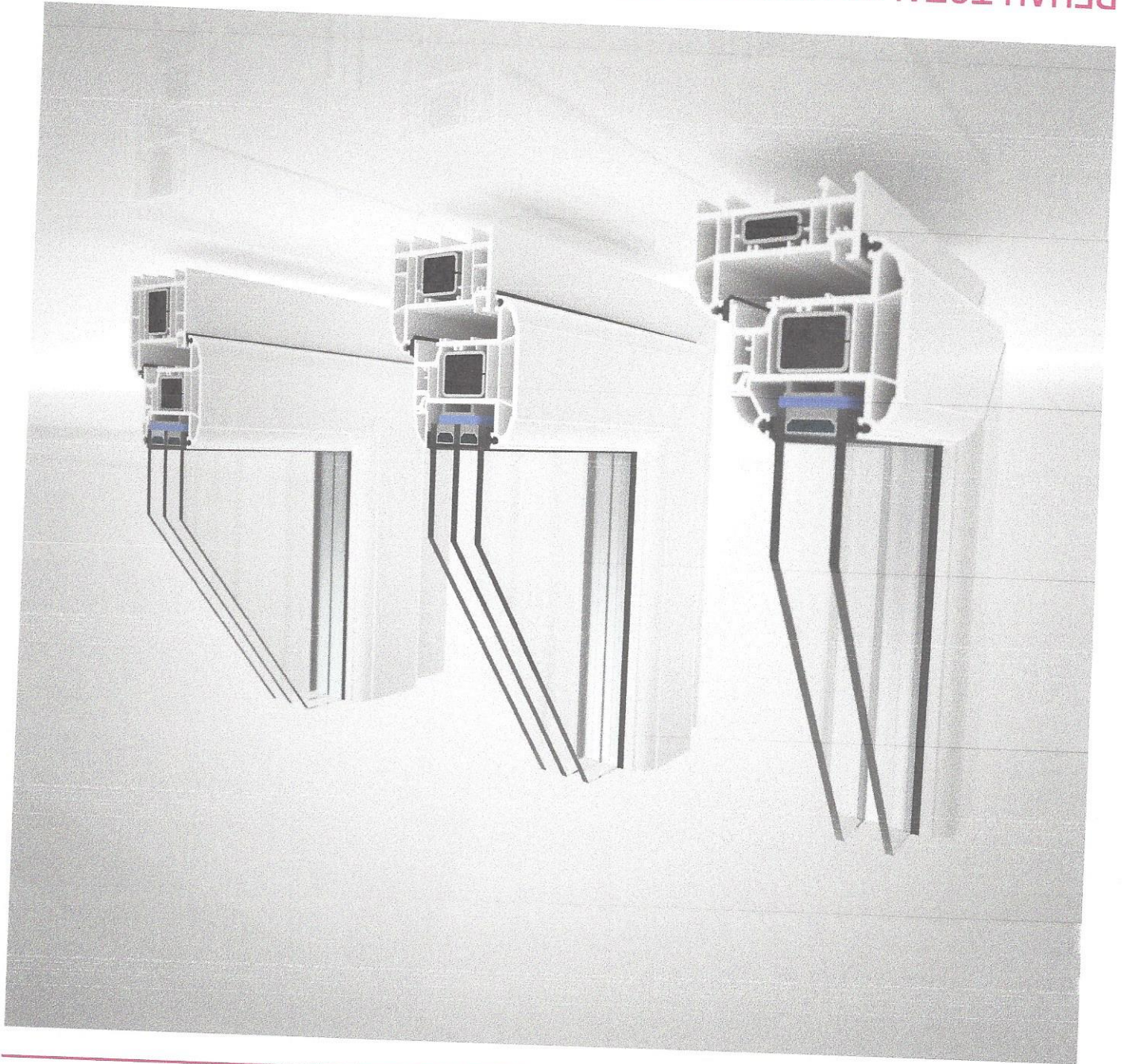

MEMO TOTAL70 WINDOW AND DOOR SYSTEMS GLAZING RECOMMENDATIONS

CONTENTS

General guidelines	4
Glazing beads and Gasket details	
Co-extruded Glazing beads	5
Glazing beads with insertable gasket	6
Single glass glazing options	6
Glazing bead and Gasket tables	7
Drainage	
Drainage and pressure equalisation	8
Drainage paths	9
RAUSECUR and sealed unit wedging instructions	
RAUSECUR installation instructions	10
Sealed unit packing instructions	11
REHAU TOTAL70 Glass deductions for Leaded/Georgian sealed units	
Internally glazed	12
Externally glazed	13
Tilt & Turn	14
Doors	14
Door and Side panels	15
French Doors	15

Introduction

Glazing gaskets should be applied in one full length and cut approximately 1% oversize. This is then glued at the centre of the top member. The correct glazing gaskets and beads for each glass thickness can be obtained from the relevant tables (refer to pages 5-7)

Only REHAU supplied gaskets should be used. The use of non-REHAU gaskets will invalidate any warranty or third party certification and the correct sealing pressures cannot be ensured.

The regulations of the glazing unit manufacturers and BS6262 requirements should be considered. Additionally, where glazing takes place on site, sashes should not be removed from frames.

At temperatures below 5°C extreme care should be taken when glazing as PVC-U becomes more brittle in these conditions.

The gap between the edge of the glass and the bottom of the rebate should be at least 6mm. The glazing units must be properly packed according to the sash type, at a maximum 100mm from the corners, and evenly supported. The packers must not inhibit the drainage route and should be secured with an adhesive material to prevent slippage (See Page 11). After the packing is completed the sashes must be checked and in correct working order. If the sashes bind, the packers should be adjusted.

To avoid corner stresses, oversize beads should not be inserted and only a non-metallic hammer may be used to snap the beads in. To remove the glass, remove the glazing seal before unclipping the bead. The longest beads

gasket Art. No. 576130 on the inside.

beads.

should be removed first by inserting a tool at the mid-point and easing out. Care should be taken at all times not to damage the beads. This applies especially to foiled or painted

Scribed Method

The beads installed by the scribed method are applied as follows:

- The horizontal beads are square cut, with the vertical beads cut at an angle to overlap the horizontal ones.
- Shaped beads are better scribed by end milling the vertical beads to give the appropriate form.
- Silicone sealant must be applied between the square cut end bead and the rebate corner. Also, the joining of the beads at the corners must be sealed.



Coloured and Foiled beads must always be scribed

Types of Glazing

Internal glazing

Co-extruded glazing beads are fitted to the inside with RAU-SIK, EPDM or foam glazing seals on the outside.

External glazing

Co-extruded beads are fitted to the outside with RAU-SIK, EPDM or foam glazing seals on the inside.

For both internal and external glazing when using non-co-extruded beads, glazing gaskets in either RAU-SIK, EPDM or foam are inserted inside and outside. The wedge gaskets are used on the inside only.

Security Gasket

For increased security against intrusion when externally glazing windows, use the security gasket Art. No. 576130 on the inside.

Integral Gasket (IG)

All profiles are supplied with Integral Gasket. The gasket width is predetermined, therefore is suited to the most common glazing thicknesses.

For glazing unit thicknesses that recommend a manually inserted gasket the Integral Gasket will need to be removed and replaced.

By only changing the bead, this may result in over/under compression of the Integral Gasket and therefore loose or tight fitting glazing units.

Glazing Rebate

Ventilation and drainage of the glazing rebate is achieved through slot-shaped apertures 5x25mm, in accordance with the cross-section, page 8 and 9. The necessary ventilation in the upper sash transverse member is also achieved by milling slots.

Pressure Equalisation and Drainage of

REHAU TOTAL/0 WINDOW AND DOOR SYSTEMS

GLAZING RECOMMENDATIONS

GLAZING BEADS AND GASKET DETAILS

Co-extruded glazing beads and Sealed Unit Glazing options

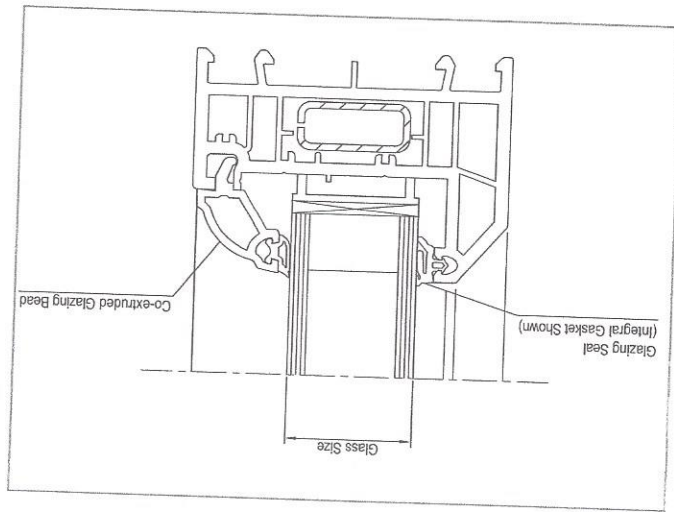

Glass size (mm)	Glazing bead (GB)	Gasket (G)
8	GB 36,5	G 5 or 38
9	GB 36,5	G 4
10	GB 36,5	G ⁺ or 3 or 36/46 or 70/71 (or IG)
11	GB 36,5	G 2 or 46
12	GB 36,5	G 1
18	GB 26,5	G 5 or 38
19	GB 26,5	G 4
20	GB 26,5	G ⁺ or 3 or 36/46 or 70/71 (or IG)
21	GB 26,5	G 2 or 46
22	GB 22,5	G 5 or 38
23	GB 22,5	G 4
24	GB 22,5	G ⁺ or 3 or 36/46 or 70/71 (or IG)
25	GB 22,5	G 2 or 46
26	GB 18,5	G 5 or 38
27	GB 18,5	G 4
28	GB 18,5	G ⁺ or 3 or 36/46 or 70/71 (or IG)
29	GB 18,5	G 2 or 46
30	GB 14,5	G 5 or 38
31	GB 14,5	G 4
32	GB 14,5	G ⁺ or 3 or 36/46 or 70/71 (or IG)
33	GB 14,5	G 2 or 46
34	GB 10,5	G 5 or 38
35	GB 10,5	G 4
36	GB 10,5	G ⁺ or 3 or 36/46 or 70/71 (or IG)
37	GB 10,5	G 2 or 46
38	GB 6,5	G 5 or 38
39	GB 6,5	G 4
40	GB 6,5	G ⁺ or 3 or 36/46 or 70/71 (or IG)
41	GB 6,5	G 2 or 46
42	GB 6,5	G 1
44	GB 7,8	G ⁺ or 3 or 36/46 or 70/71 (or IG)

© REHAU

706.630EN

08.2015



BS5713 (Specification for Hermetically Sealed Flat Double Glazing Units) permits a tolerance of ± 1 mm for overall

thickness of sealed units. When referring to the glazing tables ensure that the actual sealed unit thickness is for the correct

gaskets selected.

Due to the manufacturing tolerances, if glazing proves too

loose or tight select the next size of gasket, larger or smaller as

appropriate.

⁺Denotes RAUSECUR gasket Art. No. 576130. RAUSECUR is

recommended in all external glazing options.

GLAZING RECOMMENDATIONS
GLAZING BEADS AND GASKET DETAILS

Glazing beads with insertable gasket and sealed unit glazing options

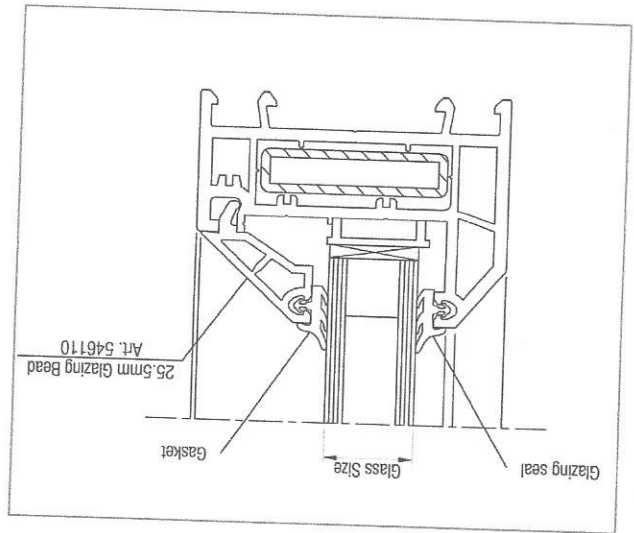

Single Glass Glazing options

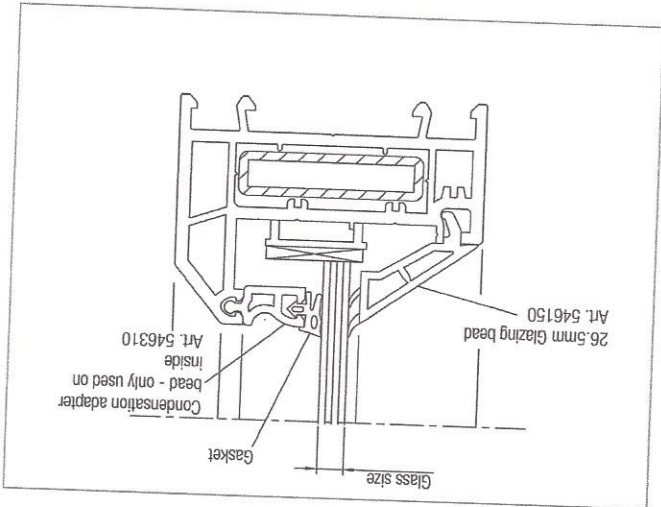
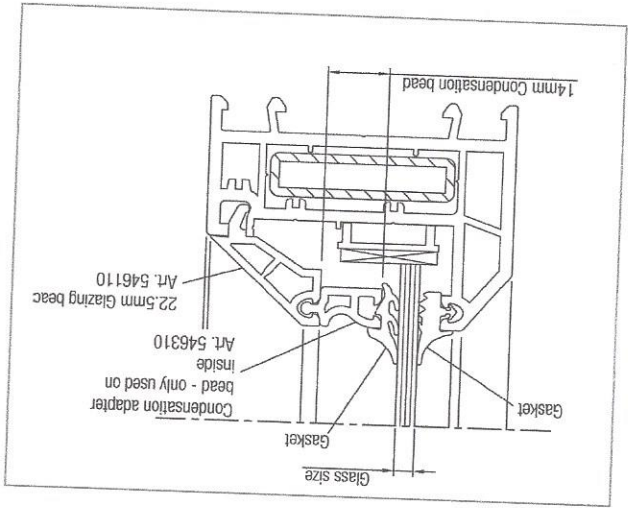

Glass size (mm)	Glazing bead (GB)	Gasket (G)
3	GB 25.5 + 546310	G 12+20 or 52+60
4	GB 25.5 + 546310	G 12+20 or 52+60
5	GB 25.5 + 546310	G 12+20 or 52+60
6	GB 25.5 + 546310	G 11+20 or 51+60
7	GB 25.5 + 546310	G 11+20 or 51+60
8	GB 25.5 + 546310	G 11+20 or 51+60

Glass size (mm)	Glazing bead (GB)	Gasket (G)
4	GB 26.5 + 546310	G 5 or 38
5	GB 26.5 + 546310	G 4
6	GB 26.5 + 546310	G 3 or 36/46
7	GB 26.5 + 546310	G 2 or 46



Drainage holes in the condensation bead are not necessary when the bead is square cut. This will allow the water to run to both ends.

* Denotes availability as a special order. Minimum order quantities may apply. Please contact your regional sales office for further information.



Glazing bead identification	Art No.	Drawing
EPDM Gaskets		
G 1	Black 864010*	
G 2	Black 864000 White 241071	
G 3	Black 863990 White 241081	
G 4	Black 863980* White 241091*	
G 5	Black 864260	

GASKETS TABLE

Glazing bead identification	Scribed bead angle	Art. No	Drawing
Glazing bead with gasket groove			
GB 25.5	41.5°	White 546110 Foilied 576290*	
Co-extruded flipper glazing beads			
GB 6.5	24.8°	White 560580 Foilied 594330	
GB 7.8		White 546860 Foilied 586865	
GB 10.5		White 503720 Foilied 573720*	
GB 14.5		White 503681 Foilied 573679	
GB 22.5	39°	White 546140 Foilied 576320	
GB 26.5	35.0°	White 546150 Foilied 576330*	
	10.7°	White 560620	
GB 36.5	7.8°	White 560660	
Low level 'Bubble' glazing beads			
GB 18.5	44.5°	White 546132 Foilied 576132	
		White 546572 Foilied 576572	

GLAZING BEAD TABLE

Glazing bead identification	Art No.	Drawing
G 36	Black 864780	
G 38	Black 864790*	
Silicone gasket		
G 46	White 833991	
EPDM single glazing gaskets		
G 11	Black 864440	
G 12	Black 864450*	
G 20	Black 864460	
Silicone single glazing gaskets		
G 51	White 836880*	
G 52	White 836890	
G 60	White 836900	
Foam gasket		
G 70	Black 240542 White 240532	
G 71	Black 279316	
Casement gaskets		
Black EPDM	863930	
White silicone	835090	
Black EPDM	863940*	
Black EPDM White EPDM (Common window gasket)	864670 241061	
Black EPDM White EPDM (Common T&T/door gasket)	864610 241051	
Black EPDM	864230	
Black EPDM	864350*	
Black Foam	241141	
White Foam	241131	

RECOMMENDATIONS FOR TOTAL WINDOW AND DOOR SYSTEMS

GLAZING RECOMMENDATIONS

DRAINAGE

Drainage and Pressure Equalisation

Sash with Transom/Mullion

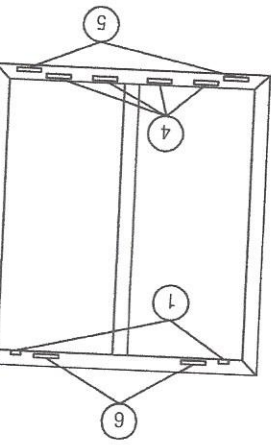
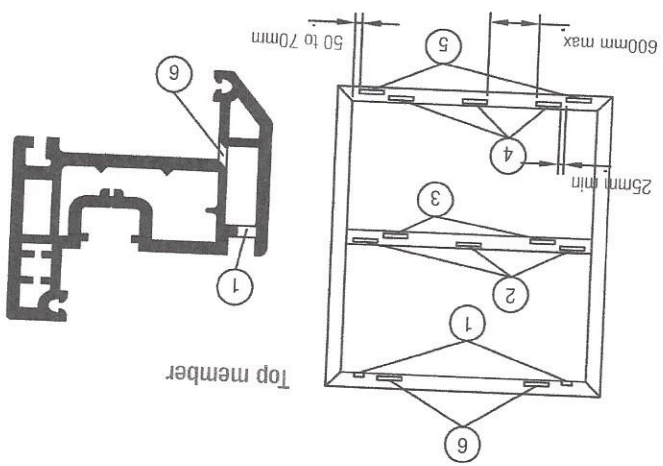

Transom

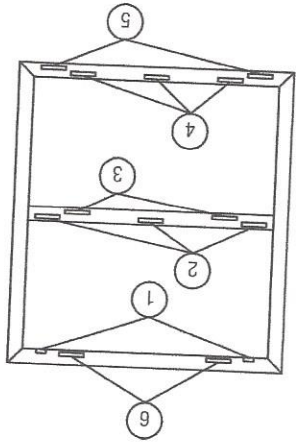
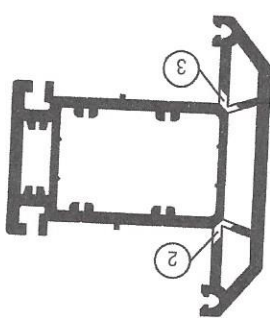

Fixed glazing in Subframe with Transom/Mullion

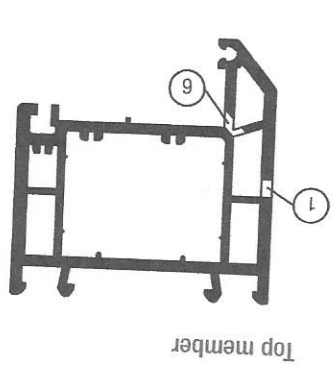

Top member

① Optional detail to optimise ventilation

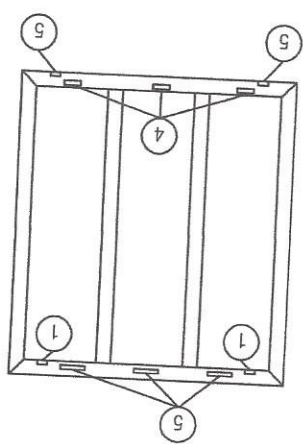

Bottom member

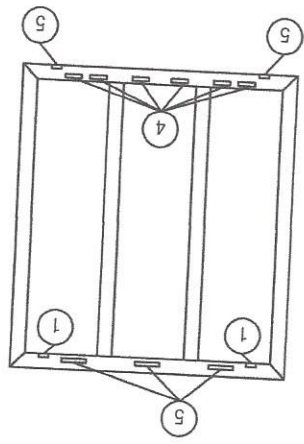
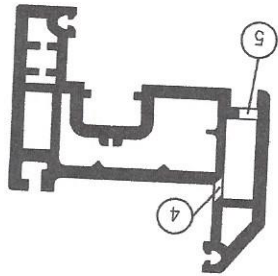

Bottom member

